

ENVIRONMENTAL-5000 PSI MATED OR HERMETIC-5000 PSI OPEN FACE RECEPTACLE

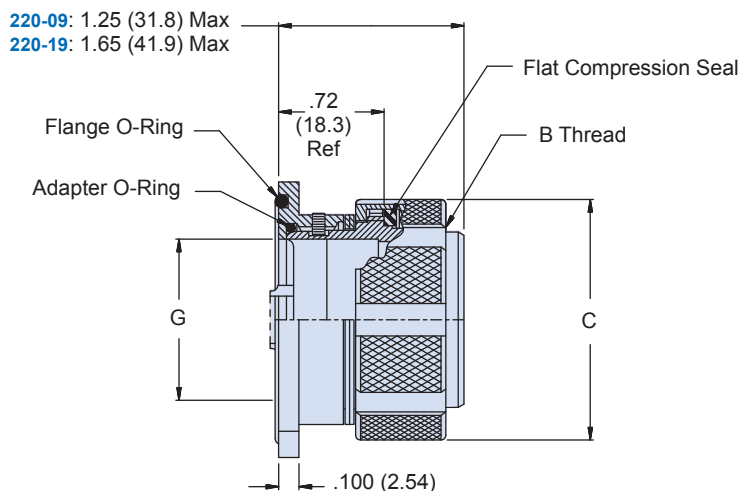

How To Order					
Sample Part Number	220-09	E	24-61	P	N
Series and Shell Style	220-09 - Standard 220-19 - Scoop-Proof				
Class	E = High-Pressure Environmental				
Shell Size - Contact Arrangement	See pages 65-66				
Contact Style	P = Pin S = Socket				
Polarization	N, 1, 2, 3, 4 See page 65				

SUBSEA/SHALLOW WATER: GEO-MARINE®

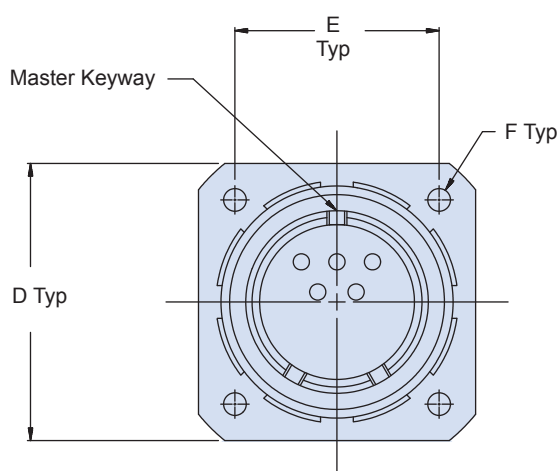

Dimensions							
Shell Size	B Thread Class 2B	C Dia Max	D Dim	E Dim	F Dia	Mtg Screw Ref.	G Panel Cutout
10	.750 - .1P - .1L	1.000 (25.4)	1.09 (27.7)	.844 (21.4)	.125 (3.2)	No. 4	.625 (15.9)
12	.875 - .1P - .1L	1.125 (28.6)	1.19 (30.2)	.938 (23.8)	.125 (3.2)	No. 4	.750 (19.1)
14	1.000 - .1P - .1L	1.250 (31.8)	1.25 (31.8)	1.000 (25.4)	.125 (3.2)	No. 4	.875 (22.2)
16	1.125 - .1P - .1L	1.375 (34.9)	1.34 (34.0)	1.094 (27.8)	.125 (3.2)	No. 4	1.000 (25.4)
18	1.250 - .1P - .1L	1.594 (40.5)	1.44 (36.6)	1.188 (30.2)	.125 (3.2)	No. 4	1.125 (28.6)
20	1.375 - .1P - .1L	1.719 (43.7)	1.55 (39.4)	1.281 (32.5)	.125 (3.2)	No. 4	1.250 (31.8)
22	1.500 - .1P - .1L	1.844 (46.8)	1.72 (43.7)	1.375 (34.9)	.125 (3.2)	No. 4	1.375 (34.9)
24	1.625 - .1P - .1L	1.969 (50.0)	1.85 (47.0)	1.500 (38.1)	.156 (4.0)	No. 6	1.500 (38.1)

Seal Replacement Part Numbers

Shell Size	Adapter O-Ring	Flange O-Ring	Compression Flat Seal	18	2-022	2-025	G70653-18
10	2-014	2-019	G70653-10	22	2-026	2-029	G70653-22
12	2-016	2-021	G70653-12	24	2-028	2-030	G70653-24
14	2-018	2-022	G70653-14	*Parker O-ring part numbers.			
16	2-020	2-024	G70653-16	Compound N674-70 or equivalent.			