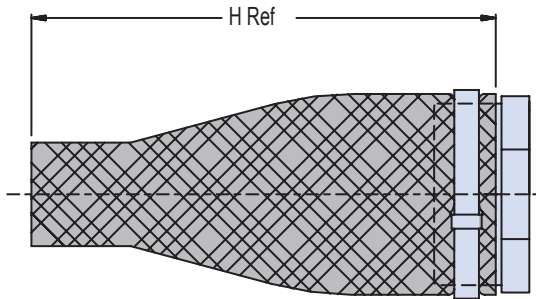

**TABLE I: Dash Number and Dimensions**

Dash No.	A Thread Class 2A	B Max	C +.010 (0.25) -0	D +.010 (0.25) -0	E +.010 (0.25) -0	F	G Max	H Min	Max Cable Entry	MIL-I-23053 Shrink Sleeve	MIL-I-23053 Shrink Sleeve	Braid Sock 103-005-005 Ref
01	3/4-20 UNEF	1.140 (29.0)	.340 (8.6)	.755 (19.2)	.691 (17.6)	.938 (23.8)	1.004 (25.5)	6.0	.335 (8.5)	/4-204-0	/5-109-0	A10
02	3/4-20 UNEF	1.140 (29.0)	.460 (11.7)	.755 (19.2)	.691 (17.6)	.938 (23.8)	1.132 (28.8)	6.0	.455 (11.6)	/4-204-0	/5-109-0	A10
03	7/8-20 UNEF	1.280 (32.5)	.630 (16.0)	.880 (22.4)	.816 (20.7)	1.062 (27.0)	1.343 (34.1)	6.0	.625 (15.9)	/4-205-0	/5-110-0	A10
04	1 1/16-18 UNEF	1.490 (37.8)	.755 (19.2)	1.067 (27.1)	1.004 (25.5)	1.250 (31.8)	1.468 (37.3)	6.0	.750 (19.1)	/4-206-0	/5-110-0	A14
05	1 3/16-18 UNEF	1.640 (41.7)	.880 (22.4)	1.192 (30.3)	1.130 (28.7)	1.375 (34.9)	1.593 (40.5)	6.0	.875 (22.2)	/4-506-0	/5-111-0	A16
06	1 5/16-18 UNEF	1.930 (49.0)	1.005 (25.5)	1.137 (28.9)	1.254 (31.9)	1.625 (41.3)	1.656 (42.1)	6.0	1.000 (25.4)	/4-305-0	/5-111-0	A18

**630-015**  
**Fiber Optic Bulkhead Feed-Through Adapter**  
**Cable with Kevlar**



**447-822\*\*\* ASSEMBLY**  
**Style T see P/N Development**

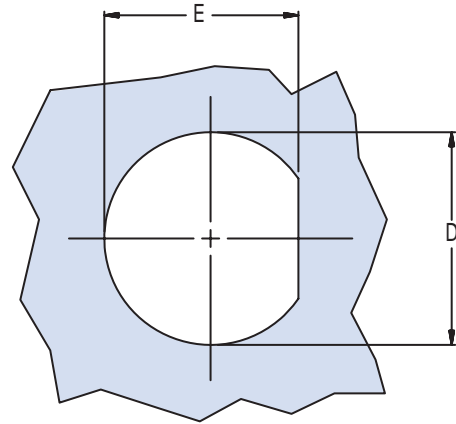

**RECOMMENDED PANEL CUT-OUT**

TABLE I: Finish	
Symbol	Description
<b>B</b>	Cadmium Plate/Olive Drab
<b>M</b>	Electroless Nickel
<b>N</b>	Cadmium Plate/Olive Drab over Nickel
<b>NF</b>	Cad/O.D. over Electroless Nickel (1,000 Hr. Salt Spray)

APPLICATION NOTES	
1.	Assembly identified with manufacturer's code identification number (Glenair, part number and classification code 490).
2.	Glenair series 600 backshell assembly tools are recommended for assembly and installation.
3.	Material / Finish: Adapters, Jam Nut, Ferrule, Coupling Nut - Al alloy/see Table I. Hardware - 316 SST/passivate. Seals and gaskets - Silicone/N.A. Mounting Plate - 300 series SST/passivate.
4.	MIL-T-23053/4 & /5 shrink sleeving to be packaged loose in a plastic bag.
5.	Metric dimensions (mm) are indicated in parentheses.

