

**Style 1**  
**Rear Mount Type A**  
**RFI/EMI**  
 (Shown With Style F Strain Relief)

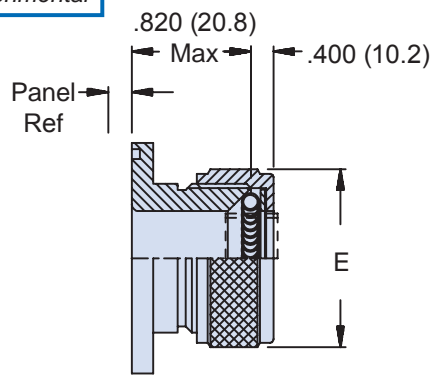

**Style 1**  
**Front Mount Type B**  
**RFI/EMI**  
 (Shown With Style G Gland Nut)

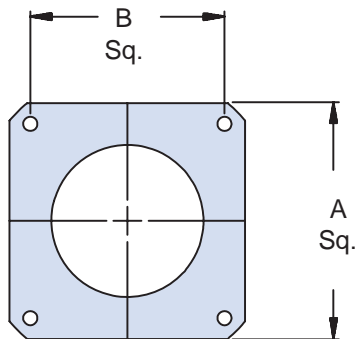

469-001-XX Shield Support Ring (order separately) is recommended for use in all G-Spring Bulkhead Fittings

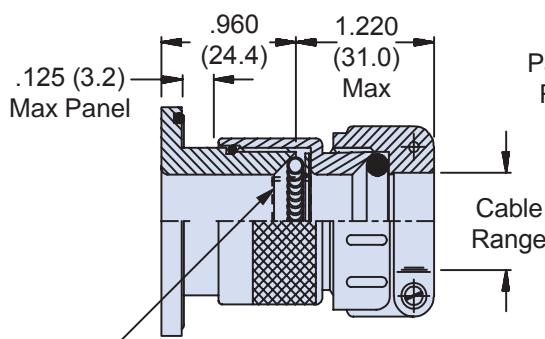

**Style 2**  
**Rear Mount Type A**  
**RFI/EMI Environmental**  
 (Shown With Style F Strain Relief)

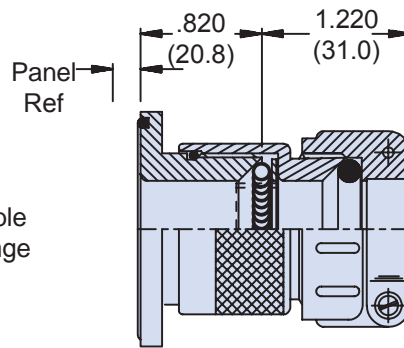

**Style 2**  
**Front Mount Type B**  
**RFI/EMI Environmental**  
 (Shown With Style F Strain Relief)

**630-005**  
**Square Flange Feed-Through Fittings**  
 "G"=Spring RFI/EMI Environmental



**TABLE III: Dash Number, Cable Range and Dimensions (Continued Below)**

Dash No.	Cable Range		A Max	B Dim	C	
	Min	Max			+0.015 (-0)	+0.4 (-0.0)
01	.156 (4.0)	.250 (6.4)	.885 (22.5)	.593 (15.1)	.120 (3.0)	(3.0)
02	.188 (4.8)	.375 (9.5)	1.104 (28.0)	.812 (20.6)	.120 (3.0)	(3.0)
03	.250 (6.4)	.438 (11.1)	1.197 (30.4)	.906 (23.0)	.120 (3.0)	(3.0)
04	.280 (7.1)	.500 (12.7)	1.291 (32.8)	.968 (24.6)	.120 (3.0)	(3.0)
05	.375 (9.5)	.625 (15.9)	1.385 (35.2)	1.062 (27.0)	.120 (3.0)	(3.0)
06	.500 (12.7)	.750 (19.1)	1.635 (41.5)	1.250 (31.8)	.120 (3.0)	(3.0)
07	.625 (15.9)	.875 (22.2)	1.760 (44.7)	1.375 (34.9)	.147 (3.7)	(3.7)
08	.750 (19.1)	1.000 (25.4)	2.010 (51.1)	1.562 (39.7)	.147 (3.7)	(3.7)
09	.875 (22.2)	1.125 (28.6)	2.260 (57.4)	1.750 (44.5)	.173 (4.4)	(4.4)
10	1.000 (25.4)	1.250 (31.8)	2.510 (63.8)	1.938 (49.2)	.173 (4.4)	(4.4)
11	1.125 (28.6)	1.375 (34.9)	2.760 (70.1)	2.125 (54.0)	.173 (4.4)	(4.4)

**TABLE III: (Continued from Above)**

Dash No.	D Max	E Max	F		G	
			+0.015 (-0)	+0.4 (-0.0)	+0.031 (-0)	+0.8 (-0.0)
01	.843 (21.4)	.625 (15.9)	.515 (13.1)	(13.1)	.250 (6.4)	(6.4)
02	.968 (24.6)	.750 (19.1)	.640 (16.3)	(16.3)	.375 (9.5)	(9.5)
03	1.046 (26.6)	.875 (22.2)	.765 (19.4)	(19.4)	.438 (11.1)	(11.1)
04	1.156 (29.4)	1.000 (25.4)	.890 (22.6)	(22.6)	.500 (12.7)	(12.7)
05	1.218 (30.9)	1.125 (28.6)	1.015 (25.8)	(25.8)	.625 (15.9)	(15.9)
06	1.343 (34.1)	1.250 (31.8)	1.140 (29.0)	(29.0)	.750 (19.1)	(19.1)
07	1.468 (37.3)	1.375 (34.9)	1.265 (32.1)	(32.1)	.875 (22.2)	(22.2)
08	1.593 (40.5)	1.500 (38.1)	1.390 (35.3)	(35.3)	1.000 (25.4)	(25.4)
09	1.718 (43.6)	1.625 (41.3)	1.515 (38.5)	(38.5)	1.125 (28.6)	(28.6)
10	1.843 (46.8)	1.750 (44.5)	1.640 (41.7)	(41.7)	1.250 (31.8)	(31.8)
11	2.187 (55.5)	1.875 (47.6)	1.765 (44.8)	(44.8)	1.375 (34.9)	(34.9)

**APPLICATION NOTES**

1. Assembly identified with manufacturer's name and part number, space permitting.
2. Cable range is defined as the accommodations range for the wire bundle or cable. Dimensions shown are not intended for inspection criteria.
3. Material / Finish: See Table II.
4. For proper termination, it is recommended that Glenair 469-001 shield support ring be used on all assemblies. Place ring over wire and under shield; position under G-spring. Please consult factory for more information.
5. "G"-spring fittings are not available in composite thermoplastic.
6. Metric dimensions (mm) are indicated in parentheses.